

METALMASTER

OPERATION MANUAL



Motorised Swage & Jenny

Models. SJM-2.5, SJM-4.0

Order Code S636, Order Code S637

Edition No : SJM-2.5,4.0-1

Date of Issue : 09/2020

www.machineryhouse.com.au

MACHINE DETAILS

MACHINE	<input type="text" value="MOTORIZED SWAGE & JENNY"/>
MODEL NO.	<input type="text"/>
SERIAL NO.	<input type="text"/>
DATE OF MANF.	<input type="text"/>

Distributed by



www.machineryhouse.com.au

www.machineryhouse.co.nz

Note:

This manual is only for your reference. Owing to the continuous improvement of the Metalmaster machine, changes may be made at any time without obligation or notice. Please ensure the local voltage is the same as listed on the specification plate before operating any electric machine.



NOTE:

In order to see the type and model of the machine, please see the specification plate. Usually found on the back of the machine. See example (Fig.1)

METALMASTER	
PRODUCT SPECIFICATION	
MODEL:	<input type="text"/>
CAPACITY:	<input type="text"/>
SER. NO:	<input type="text"/>
MFG DATE:	<input type="text"/>
WEIGHT:	<input type="text"/>
VOLTS:	<input type="text"/>
MOTOR Kw:	<input type="text"/>
www.machineryhouse.com.au Made in China	

Fig.1

CONTENTS:

1. GENERAL MACHINE INFORMATION	
1.1 Specifications.....	4
1.2 Standard Equipment.....	4
1.3 Identification.....	5
1.4 SJM-2.5 Dimensions.....	6
1.5 SJM-4.0 Dimensions.....	7
2. IMPORTANT INFORMATION	
2.1 Safety Requirements.....	9
2.2 Safety Features of the Machine.....	11
2.3 Lifting Instructions.....	12
3. SETUP	
3.1 Clean Up.....	13
3.2 Site Preparation.....	13
3.3 Leveling The Machine.....	14
3.4 Electrical Installation.....	14
3.5 Full Load Current Rating.....	15
3.6 Test Run.....	15
4. OPERATION	
4.1 Controls.....	16
4.2 Changing The Rolls.....	17
4.3 Rolls Alignment.....	18
4.4 Adjusting The Fence Position.....	18
5. MAINTENANCE	
5.1 Schedule.....	19
5.2 Lubrication.....	19
5.3 Troubleshooting.....	20
Spare Parts.....	21
Risk Assessment Sheets.....	29

1.1 SPECIFICATION

Order Code	S636	S637
MODEL	SJM-2.5	SJM-4.0
Mild Steel - Thickness Capacity (mm/gauge)	2.5 / 12	4.0 / 8
Throat Depth Maximum (mm)	360	380
Roll Diameter (mm)	90	128
Main Shafts Diameters (mm)	60	80
Output Drive Speed (rpm)	20	15
Motor Power (kW/hp)	1.5 / 2	2.2 / 3
Voltage (V)	415	415
Amperage (amp)	15	15
Dimensions (L x W x H) (cm)	139 x 51 x 114	155 x 51 x 118
Nett Weight (kg)	296	403

1.2 ACCESSORIES INCLUDED

Roving foot pedal control
Adjustable depth guide
Spanner

SJM-2.5 Roll Sets:

1 set of S1 Cutting Rolls
1 set of S2 Criming Rolls
1 set of S3 Wiring Rolls
1 set of S4 Necking Rolls

SJM-4.0 Roll Sets:

1 set of S1 Cutting Rolls
1 set of S2 Necking Rolls 8mm
1 set of S3 Wiring Rolls
1 set of S4 Necking Rolls 10mm



1.3 IDENTIFICATION

1	Main Body	7	Roving Foot Pedal
2	Emergency Stop Button	8	Forward & Reverse Pedals
3	ON Switch	9	Bottom Roll Horizontal Adjustment
4	OFF Switch	10	Material Guide
5	Power ON Light	11	Rolls
6	Isolating Switch	12	Top Roll Vertical Adjustment

1.4 SJM-2.5 DIMENSIONS

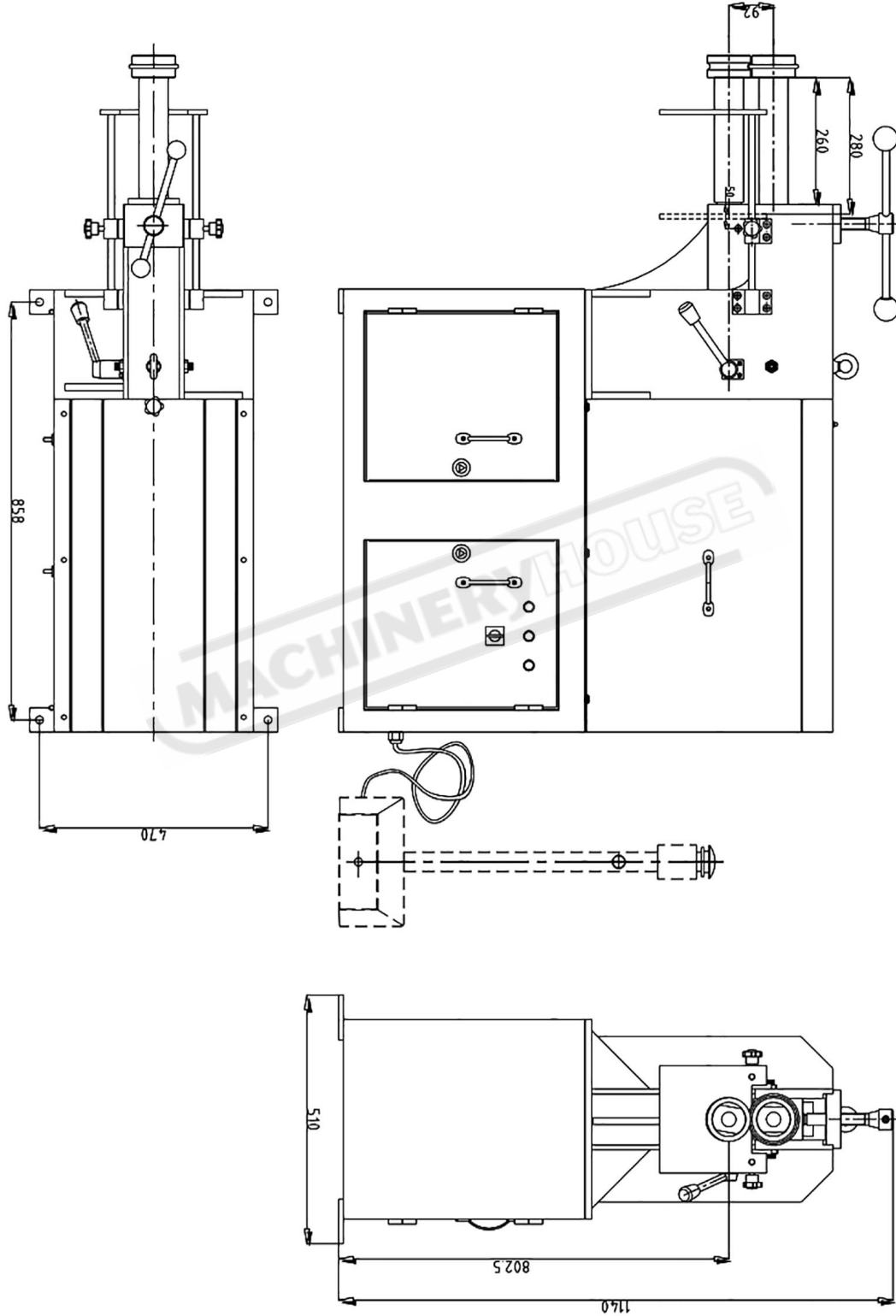

1.5 SJM-4.0 DIMENSIONS

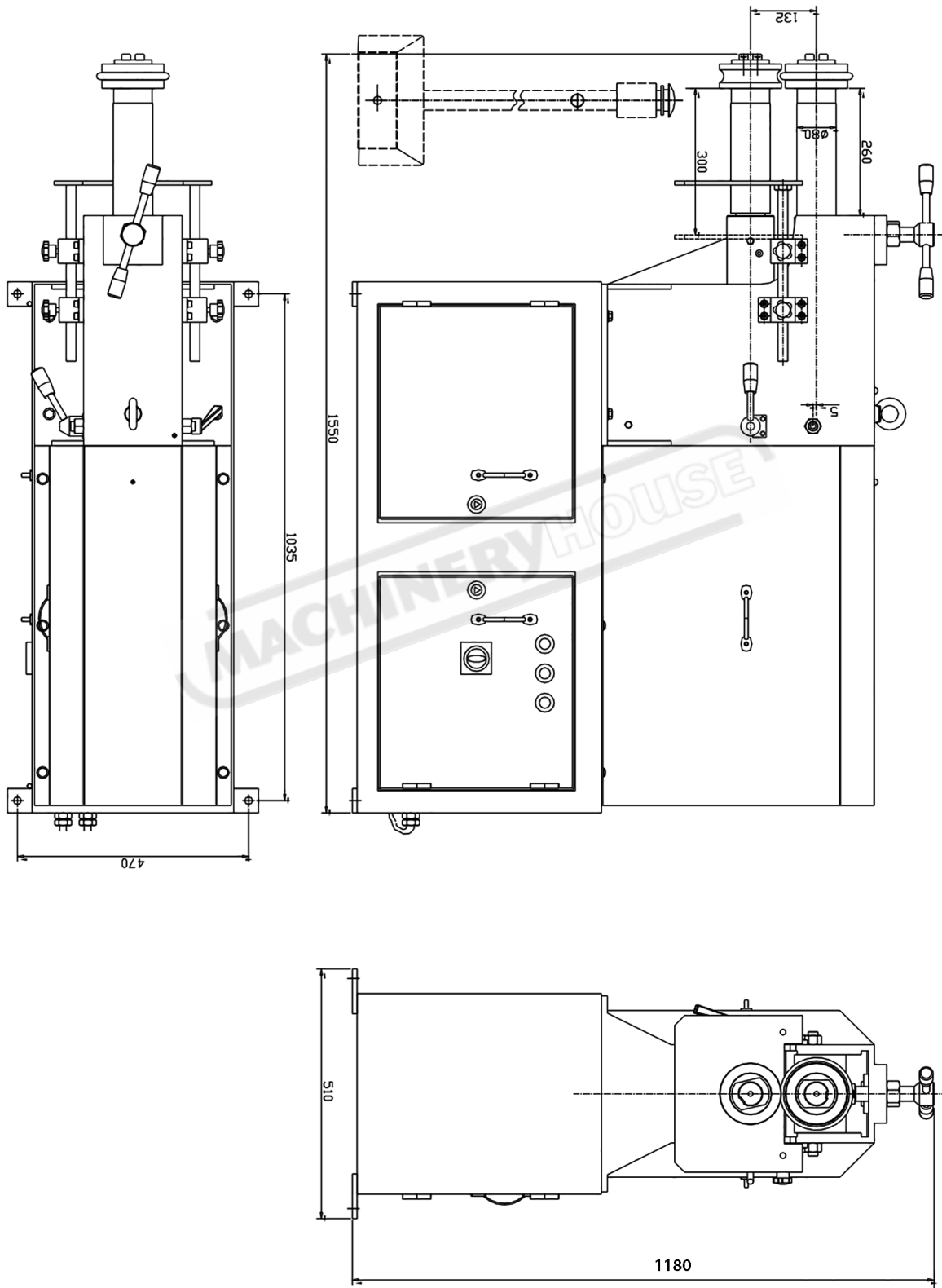

2.1 GENERAL METALWORKING MACHINE SAFETY

DO NOT use this machine unless you have read this manual or have been instructed in the use of this machine in its safe use and operation



WARNING

This manual provides safety instructions on the proper setup, operation, maintenance, and service of this machine. Save this manual, refer to it often, and use it to instruct other operators. Failure to read, understand and follow the instructions in this manual may result in fire or serious personal injury—including amputation, electrocution, or death.

The owner of this machine is solely responsible for its safe use. This responsibility includes, but is not limited to proper installation in a safe environment, personnel training and authorization to use, proper inspection and maintenance, manual availability and comprehension, of the application of the safety devices, integrity, and the use of personal protective equipment.

The manufacturer will not be held liable for injury or property damage from negligence, improper training, machine modifications or misuse.



- ✓ Always wear safety glasses or goggles.
- ✓ Wear appropriate safety footwear.
- ✓ Wear respiratory protection where required.
- ✓ Gloves should never be worn while operating the machine, and only worn when handling the workpiece.
- ✓ Wear hearing protection in areas > 85 dBA. If you have trouble hearing someone speak from one metre (three feet) away, the noise level from the machine may be hazardous.
- ✓ DISCONNECTION THE MACHINE FROM POWER when making adjustments or servicing.
- ✓ Check and adjust all safety devices before each job.
- ✓ Ensure that guards are in position and in good working condition before operating.
- ✓ Ensure that all stationary equipment is anchored securely to the floor.
- ✓ Ensure all machines have a start/stop button within easy reach of the operator.
- ✓ Each machine should have only one operator at a time. However, everyone should know how to stop the machine in an emergency.

2.1 GENERAL METALWORKING MACHINE SAFETY Cont.

- ✓ Ensure that keys and adjusting wrenches have been removed from the machine before turning on the power. Appropriate storage for tooling should be provided.
- ✓ Ensure that all cutting tools and blades are clean and sharp. They should be able to cut freely without being forced.
- ✓ Stop the machine before measuring, cleaning or making any adjustments.
- ✓ Wait until the machine has stopped running to clear cuttings with a vacuum, brush or rake.
- ✓ Keep hands away from the cutting head and all moving parts.
- ✓ Avoid awkward operations and hand positions. A sudden slip could cause the hand to move into the cutting tool or blade.
- ✓ Return all portable tooling to their proper storage place after use.
- ✓ Clean all tools after use.
- ✓ Keep work area clean. Floors should be level and have a non-slip surface.
- ✓ Use good lighting so that the work piece, cutting blades, and machine controls can be seen clearly. Position any shade lighting sources so that they do not cause any glare or reflections.
- ✓ Ensure there is enough room around the machine to do the job safely.
- ✓ Obtain first aid immediately for all injuries.
- ✓ Understand that the health and fire hazards can vary from material to material. Make sure all appropriate precautions are taken.
- ✓ Clean machines and the surrounding area when the operation is finished.
- ✓ Use proper lock out procedures when servicing or cleaning the machines or power tools.

DO NOT

- × Do not distract an operator. Horseplay can lead to injuries and should be strictly prohibited.
- × Do not wear loose clothing, gloves, necktie's, rings, bracelets or other jewellery that can be come entangled in moving parts. Confine long hair.
- × Do not handle cuttings by hand because they are very sharp. Do not free a stalled cutter without turning the power off first. Do not clean hands with cutting fluids.
- × Do not use rags or wear gloves near moving parts of machines.
- × Do not use compressed air to blow debris from machines or to clean dirt from clothes.
- × Do not force the machine. It will do the job safer and better at the rate for which it was designed.



BEFORE OPERATING ANY MACHINE, TAKE TIME TO READ AND UNDERSTAND ALL SAFETY SIGNS AND SYMBOLS. IF NOT UNDERSTOOD SEEK EXPLANATION FROM YOUR SUPERVISOR.

2.1 GENERAL METALWORKING MACHINE SAFETY Cont.

HAZARDS ASSOCIATED WITH MACHINES include, but are not limited to:

- Being struck by ejected parts of the machinery
- Being struck by material ejected from the machinery
- Contact or entanglement with the machinery
- Contact or entanglement with any material in motion

Health Hazards (other than physical injury caused by moving parts)

- Chemicals hazards that can irritate, burn, or pass through the skin
- Airborne items that can be inhaled, such as oil mist, metal fumes, solvents, and dust
- Heat, noise, and vibration
- Ionizing or non-ionizing radiation (X-ray, lasers, etc.)
- Biological contamination and waste
- Soft tissue injuries (for example, to the hands, arms, shoulders, back, or neck) resulting from repetitive motion, awkward posture, extended lifting, and pressure grip)

Other Hazards

- Slips and falls from and around machinery during maintenance
- Unstable equipment that is not secured against falling over
- Safe access to/from machines (access, egress)
- Fire or explosion
- Pressure injection injuries from the release of fluids and gases under high pressure
- Electrical Hazards, such as electrocution from faulty or ungrounded electrical components
- Environment in which the machine is used (in a machine shop, or in a work site)



MACHINES ARE SAFEGUARDED TO PROTECT THE OPERATOR FROM INJURY OR DEATH WITH THE PLACEMENT OF GUARDS. MACHINES MUST NOT BE OPERATED WITH THE GUARDS REMOVED OR DAMAGED.

2.2 SPECIFIC SAFETY FOR SWAGE & JENNY MACHINE

DO NOT use this machine unless you have been instructed in its safe use and operation and have read and understood this manual



Safety glasses must be worn when operating this equipment



Long and loose hair must be contained when operating this equipment.



Safety footwear must be worn when operating this equipment



Close fitting/protective clothing must be worn when operating the machine



Dust mask must be worn when operating in high dust areas.



Hearing protection must be used when operating in a noisy environment

PRE-OPERATIONAL SAFETY CHECKS

- Locate and ensure you are familiar with all machine operations and controls.
- Ensure all guards are fitted, secure and functional. Do not operate if guards are missing or faulty.
- Working parts should be well lubricated and the dies are free of rust and dirt.
- Check workspaces and walkways to ensure no slip/trip hazards are present.
- Be aware of other people in the area and ensure the area is clear before using equipment.

OPERATIONAL SAFETY CHECKS

- Adjust the chosen dies slowly and in small adjustments.
- Take care during the initial feeding of the workpiece into the dies.
- Hold the workpiece sufficiently far back from the edge being fed into the dies, to allow for the in-feed speed of the machine.
- Wind handle at a slow even rate. Be aware of rotating dies
- Only one person may operate this machine at any one time.

ENDING OPERATIONS AND CLEANING UP

- Ensure the machine is left in a safe condition after use.
- Leave the work area in a safe, clean and tidy state.

POTENTIAL HAZARDS AND INJURIES

- Sharp edges and burrs.
- Crush and pinch points.
- Hair/clothing getting caught in moving machine parts.
- Operator's hands may be caught and drawn into the rotating dies.

DON'T

- Do not use faulty equipment. Immediately stop and repair suspect machinery.
- Do not attempt to form material beyond the capacity of the machine.

2.3 LIFTING INSTRUCTIONS

On the day that the machine arrives, make sure that a crane with sufficient capacity is available to unload the machine from the vehicle. Ensure access to the chosen site is clear and that doors and ceilings are sufficiently high and wide enough to receive the machine. To handle the machine, the slings should be positioned so the machine is level when lifted. When using slings please take note of the sling angle and the loads that apply

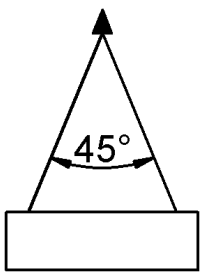

Fig 2.1.

When the slings are at a 45° angle then each sling is carrying the equivalent of 50% of load weight. (Fig.2.1).

When the slings are at a 90° angle then each sling will have a weight equal to 75% of the load on each sling. (Fig 2.2)

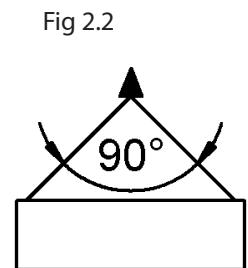

Fig 2.2

NOTE: THE MANUFACTURER RECOMMENDS NOT TO EXCEED 90° ANGLE

LIFTING POINTS

When lifting the machine only certified lifting slings should be used. Ensure that when lifting, the machine does not tip over. Check that the lifting slings do not interfere with the machines controls or electrical conduits. Failure to follow these instructions could cause damage to the machine



FIG.2.3

3. SETUP

3.1 CLEAN - UP

The unpainted surfaces of the machine have been coated with a waxy oil to protect them from corrosion during shipment. Remove the protective coating with a solvent cleaner or a citrus based degreaser.

Optimum performance from your machine will be achieved when you clean all moving parts or sliding contact surfaces that are coated with rust prevented products.

It is advised to avoid chlorine based solvents, such as acetone or brake parts cleaner, as they will damage painted surfaces and strip metal should they come in contact. Always follow the manufacturer's instructions when using any type of cleaning product.

3.2 SITE PREPARATION

When selecting the site for the machine, consider the largest size of workpiece that will be processed through the machine and provide enough space around the machine for operating the machine safely. Consideration should be given to the installation of auxiliary equipment. Leave enough space around the machine to open or remove doors/covers as required for the maintenance and service as described in this manual.

It is recommended that the machine is anchored to the floor to prevent tipping or shifting. It also reduces vibration that may occur during operation.

Machine Mounting Options

Although it is not required Metalmaster recommends that you secure your machine to the floor. Masonry anchors with bolts are the best way to anchor machinery, because the anchors sit flush with the floor surface, making it easy to unbolt and move the machine later, if needed. (Fig. 3.2) Other methods of mounting is the use of machine mounts which also help with the levelling of the machine and isolating vibration. (Fig.3.3)

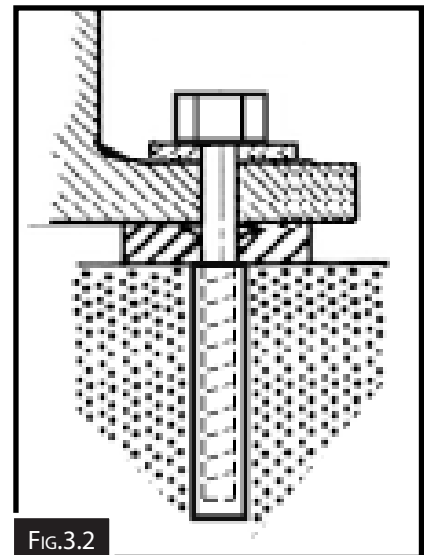

FIG.3.2

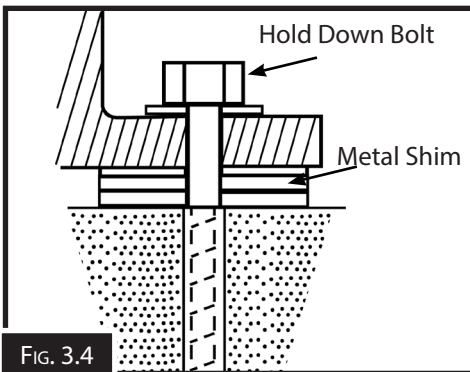

FIG.3.3

3.3 MACHINE LEVELING

To set your machine up so that it operates to optimum performance, apply the following procedure

After your machine has been anchored to a concrete slab floor, it then needs to be leveled. Loosen the hold down bolts and place a level on the surface of the working table. Metal shims need to be placed under corner of the base of the machine until level. Once level then tighten the hold down bolts. (Fig. 3.4).



The machine must not rest on supports other than those defined in Fig. 3.4

3.4 ELECTRICAL INSTALLATION

Place the machine near an existing power source. Make sure all power cords are protected from traffic, material handling, moisture, chemicals, or other hazards. Make sure there is access to a means of disconnecting the power source. The electrical circuit must meet the requirements for 415V. To minimize the risk of electrocution, fire, or equipment damage, these machines should be hard wired with installation work and electrical wiring done by a qualified electrician.

NOTE : The use of an extension cord is not recommended as it may decrease the life of electrical components on your machine.

ELECTRICAL REQUIREMENTS

Nominal Voltage.....415V

Cycle.....50 Hz

Phase.....Three Phase

Power Supply Circuit.....15 Amps

(Full load current rating is also on the specification plate on the motor.)

3.5 FULL-LOAD CURRENT RATING

The full-load current rating is the amperage a machine draws when running at 100% of the output power. Where machines have more than one motor, the full load current is the amperage drawn by the largest motor or a total of all the motors and electrical devices that might operate at one time during normal operations.

Full-Load Current Rating for these machines can be found on the specification plate. It should be noted that the full-load current is not the maximum amount of amps that the machine will draw. If the machine is overloaded, it will draw additional amps beyond the full-load rating and if the machine is overloaded for a long period of time, damage, overheating, or fire may be caused to the motor and circuitry.

This is especially true if connected to an undersized circuit or a long extension lead. To reduce the risk of these hazards, avoid overloading the machine during operation and make sure it is connected to a power supply circuit that meets the requirements.



3.6 TEST RUN

Once assembly is complete, test run the machine to ensure it is properly connected to the power and safety components are functioning correctly. Check that the direction of the rolls is correct by depressing each pedal on the roving foot pedals and make sure that the rolls are rotating in the correct direction.

If the direction is incorrect, isolate the machine and have the electrician make changes to the wiring.

Testing The Emergency Stop Button

Make sure that the emergency button has been reset.

Start the machine and then press the emergency stop button. The machine should stop and the power should be cut off. If the machine cannot be started then the emergency stop is working correctly. To reset the emergency stop twist the red top until it pops up.

If you find an unusual problem during the test run, immediately stop the machine, disconnect it from power, and fix the problem BEFORE operating the machine again. The Troubleshooting table in the Maintenance section of this manual may be able to help. If the problem persists the contact your dealers service technician.

4. OPERATION

This machine will perform many types of operations that are beyond the scope of this manual. Many of these operations can be dangerous or deadly if performed incorrectly.

The instructions in this section are written with the understanding that the operator has the necessary knowledge and skills to operate this machine. If at any time you are experiencing difficulties performing any operation, stop using the machine!

If you are an inexperienced operator, we strongly recommend that you read books, trade articles, or seek training from an experienced operator before performing any unfamiliar operations. **Above all, your safety should come first!**

4.1 CONTROLS

The purpose of this control overview is to provide the novice machine operator with a basic understanding of how the machine is used during operation, and the machine controls and what they do. It also helps the operator to understand if they are discussed later in this manual.

A. ON Button. Switches the power ON to the machine. (Fig.4.1)

B. OFF Button. Switches the power OFF to the machine.

C. Power Light. Illuminates when power is switched on.

D. Main Isolating Switch. Isolates the machine from the power supply. (Fig.4.1)

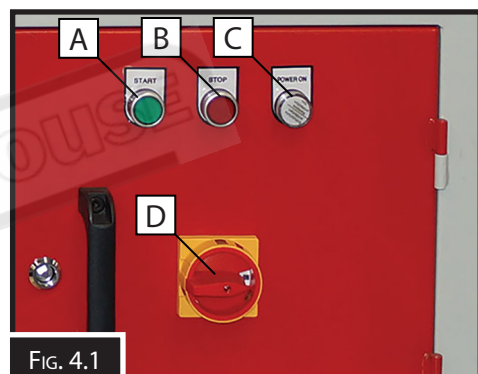

FIG. 4.1

E. Emergency Stop Button. When pressed stops the machine and locks access to the power supply. To unlock and reset the stop button twist the red top in the direction of the arrows to allow the red button to pop up. (Fig.4.2)

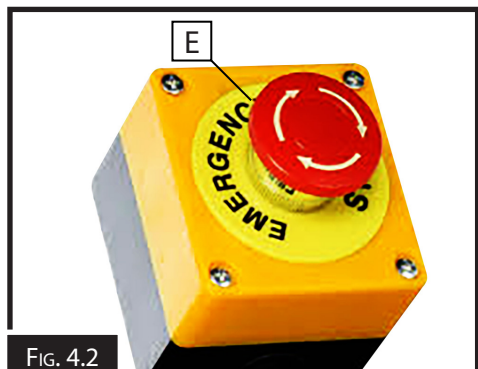

FIG. 4.2

F. Right Pedal. When pressed and held down the rolls rotate in a clock wise direction (Fig.4.3)

G. Left Pedal. When pressed and held down the rolls rotate in a anti clock wise direction (Fig.4.3)

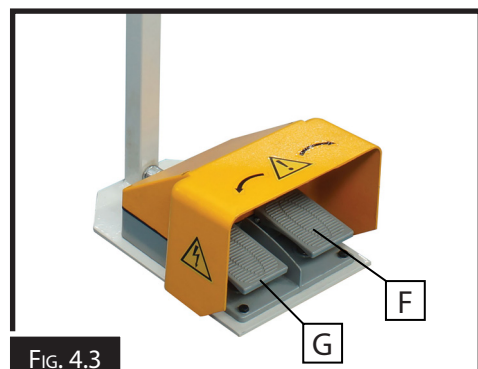
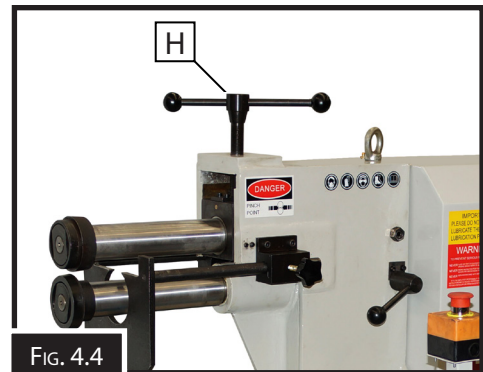

FIG. 4.3

4.1 CONTROLS Cont.

H. Top Roll Adjusting Handle. With the bottom roller being fixed, all the adjustment up and down is made by the top roll which is controlled by the handle. (Fig.4.4)



4.2 CHANGING THE ROLLS

A variety of roll sets are available for various applications that can be done on this machine. The first process that needs to be done is the selection of the roll set required, from the table below. (Fig.4.5)

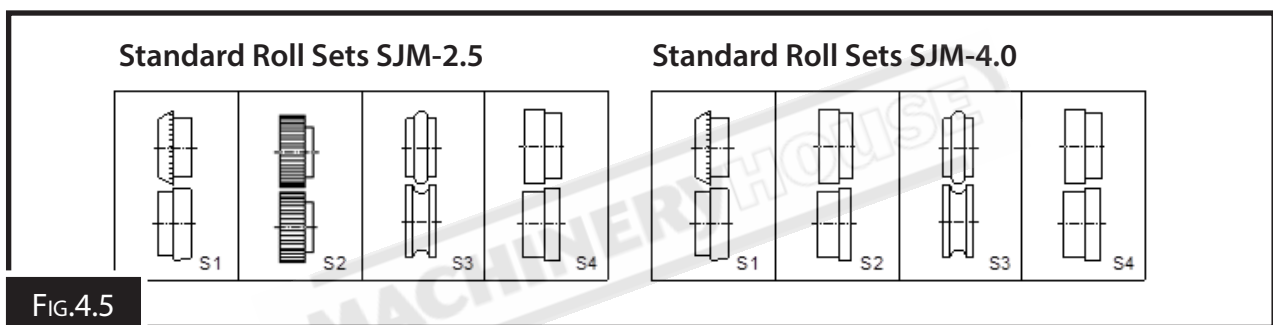

Once the roll set has been chosen then they need to be fitted to the machine.

To change the rolls,

1. DISCONNECT THE MACHINE FROM THE POWER SUPPLY
2. Use the included spanner to remove the retaining nuts (Fig.4.6)

NOTE: • *The upper retaining nut is a left-hand thread. Rotate it clockwise to loosen and counterclockwise to tighten.*

• *The lower retaining nut is a right-hand threads. Rotate it counterclockwise to loosen and clockwise to tighten.*

3. Remove the existing roll set, then install the new roll set and secure with the retaining nuts.

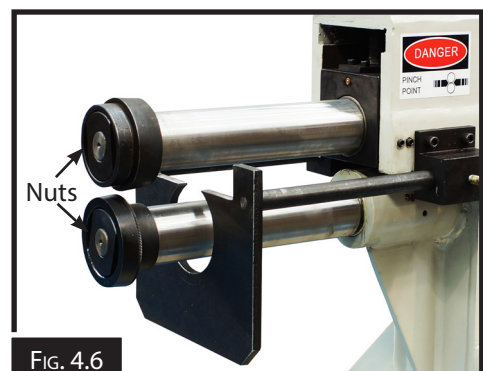

4.3 ROLLS ALIGNMENT

Before operations, and whenever you change the roll sets, always make sure the rolls are aligned to ensure properly formed beads. (Fig.4.7)

To align the mandrels,

1. Lower the upper roll until it almost touches the lower roll.
2. Adjust the lever (J in Fig. 4.8), to move the lower shaft in or out until the rolls are correctly aligned.

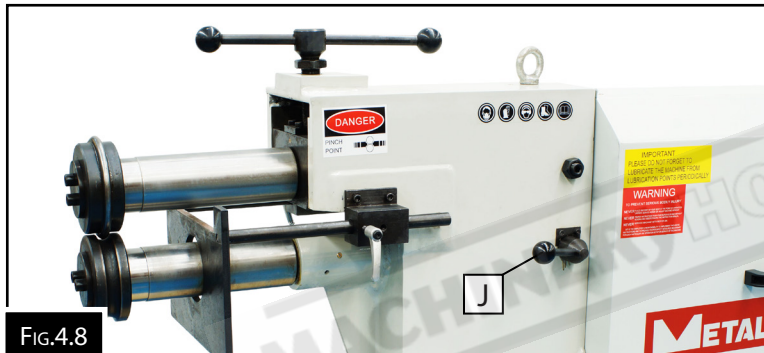

FIG.4.8

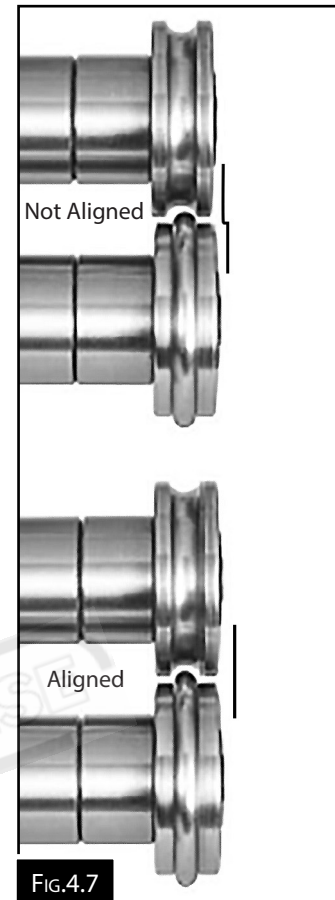

FIG.4.7

4.4 ADJUSTING THE FENCE POSITION

To create straight, consistent forms that are parallel with an edge of the workpiece, the fence is used to guide the workpiece in a straight line at a set distance from the rolls.

To adjust the fence loosen the two clamps, one on each side of the machine, then move the fence toward or away from the rolls as required, then re-tighten the two clamps. (Fig.4.10)



FIG.4.10

5. MAINTENANCE

5.1 SCHEDULE

For optimum performance from your machine, follow this maintenance schedule and refer to any specific instructions given in the maintenance section.

Daily Check

- Loose mounting bolts.
- Worn or damaged wires.
- Check/adjust lubrication.
- Any other unsafe condition.

5.2 LUBRICATION

The recommended lubrication in this manual is based on light-to-medium usage. Keeping in mind that lubrication helps to protect the value and operation of the machine, these lubrication tasks may need to be performed more frequently than recommended here, depending on usage.

Failure to follow reasonable lubrication practices as instructed in this manual could lead to premature failure of machine parts and possibly void the warranty.

1. On top of the machine and near the shafts are grease nipples that feed grease to the drive gears and bearings.
These need to be greased WEEKLY. (Fig. 5.1)



2. Unpainted machined surfaces need to be covered with a light oil to prevent rust.
These need to be covered with a light oil DAILY
3. Oil the Upper Shaft Elevation Crank thread
This needs to be covered with a light oil WEEKLY

5.2 TROUBLESHOOTING

Review the troubleshooting and procedures in this section if a problem develops with your machine. If you need replacement parts then follow the procedure in beginning of the spare parts section or if additional help with a procedure is required, then contact you distributor.

Note: Make sure you have the model of the machine, serial number, and manufacture date before calling.

Symptoms	Possible Cause	Possible Solution
Machine does not start or a breaker trips.	<ol style="list-style-type: none"> 1. Main power switch in OFF position/at fault. 2. Plug/receptacle at fault/wired wrong. 3. Incorrect power supply voltage/circuit size. 4. Power supply circuit breaker tripped or fuse blown. 5. Motor wires connected incorrectly. 6. Contactor not energized/has poor contacts. 7. Wiring open/has high resistance. 8. Foot pedal switch at fault. 9. Start capacitor at fault. 10. Centrifugal switch at fault 11. Motor at fault. 	<ol style="list-style-type: none"> 1. Rotate switch to ON position. Replace. 2. Test for good contacts; correct the wiring. 3. Ensure correct power supply voltage/circuit size. 4. Ensure circuit is sized correctly and free of shorts. Reset circuit breaker or replace fuse. 5. Correct motor wiring connections. 6. Test all legs for power/replace. 7. Check/fix broken, disconnected, or corroded wires. 8. Test/replace switch. 9. Test/replace. 10. Adjust/replace centrifugal switch if available. 11. Test/repair/replace.
Machine stalls or is underpowered.	<ol style="list-style-type: none"> 1. Machine undersized for task. 2. Wrong workpiece material. 3. Motor overheated. 4. Motor wired incorrectly. 5. Contactor not energized/has poor contacts. 6. Plug/receptacle at fault. 7. Gearbox at fault. 8. Run capacitor at fault. 9. Centrifugal switch at fault. 10. Foot pedal switch at fault. 11. Motor bearings at fault 	<ol style="list-style-type: none"> 1. Reduce downward pressure of upper roller. 2. Use correct type/size of sheet metal stock. 3. Clean motor, let cool, and reduce workload. 4. Wire motor correctly. 5. Test all legs for power/replace. 6. Test for good contacts/correct wiring. 7. Replace broken or slipping gears. 8. Test/replace. 9. Adjust/replace centrifugal switch if available. 10. Test/replace switch. 11. Test by rotating shaft; rotational grinding/loose shaft requires bearing replacement
Machine has vibration or noisy operation.	<ol style="list-style-type: none"> 1. Motor or component loose. 2. Motor fan rubbing on fan cover. 3. Motor mount loose/broken. 4. Machine incorrectly mounted on floor. 5. Roll(s) at fault/incorrectly installed. 6. Centrifugal switch at fault. 7. Motor bearings at fault. 	<ol style="list-style-type: none"> 1. Inspect/replace damaged bolts/nuts, and re-tighten with thread-locking fluid. 2. Fix/replace fan cover; replace loose/damaged fan. 3. Tighten/replace. 4. Tighten mounting bolts; relocate/shim machine. 5. Ensure rolls are correctly installed, replace if necessary. 6. Adjust/replace centrifugal switch if available. 7. Test by rotating shaft; rotational grinding/loose shaft requires bearing replacement.
Workpiece dorms, kinks, or is crushed during operation.	<ol style="list-style-type: none"> 1. Excessive rolling pressure. 2. Rolls not properly aligned. 3. Rolls(s) are damaged. 	<ol style="list-style-type: none"> 1. Reduce downward pressure of upper roll. 2. Align rolls (Page 18). 3. Replace rolls(s)
Bead is not deep enough.	<ol style="list-style-type: none"> 1. Not enough rolling pressure 	<ol style="list-style-type: none"> 1. Increase downward pressure of upper roll.
Workpiece does not move when rollers rotate.	<ol style="list-style-type: none"> 1. Not enough rolling pressure. 2. Grease/oil on workpiece/rolls, causing rolls to slip against workpiece 	<ol style="list-style-type: none"> 1. Increase downward pressure of upper roll. 2. Thoroughly clean workpiece/rolls to prevent slipping

SPARE PARTS SECTION

Motorised Swage & Jenny Models. SJM-2.5, SJM-4.0

Order Code S636, Order Code S637

Edition No : SJM-2.5,4.0-1

Date of Issue : 09/2020

The following section covers the spare parts diagrams and lists that were current at the time this manual was originally printed. Due to continuous improvements of the machine, changes may be made at any time without notification.

HOW TO ORDER SPARE PARTS

1. Have your machines **model number, serial number & date of manufacture** on hand, these can be found on the specification plate mounted on the machine
2. A scanned copy of your parts list/diagram with required spare part/s identified
3. Go to www.machineryhouse.com.au/contactus and fill out the inquiry form attaching a copy of scanned parts list.

CONTENTS

Wiring Diagram.....	22
SJM-2.5 Cabinet Diagram.....	23
SJM-2.5 Spare Parts Diagram.....	24
SJM-2.5 Spare Parts List.....	25
SJM-4.0 Cabinet Diagram.....	26
SJM-4.0 Spare Parts Diagram.....	27
SJM-4.0 Spare Parts List.....	28

SJM-2.5 CABINET SPARE PARTS DIAGRAM

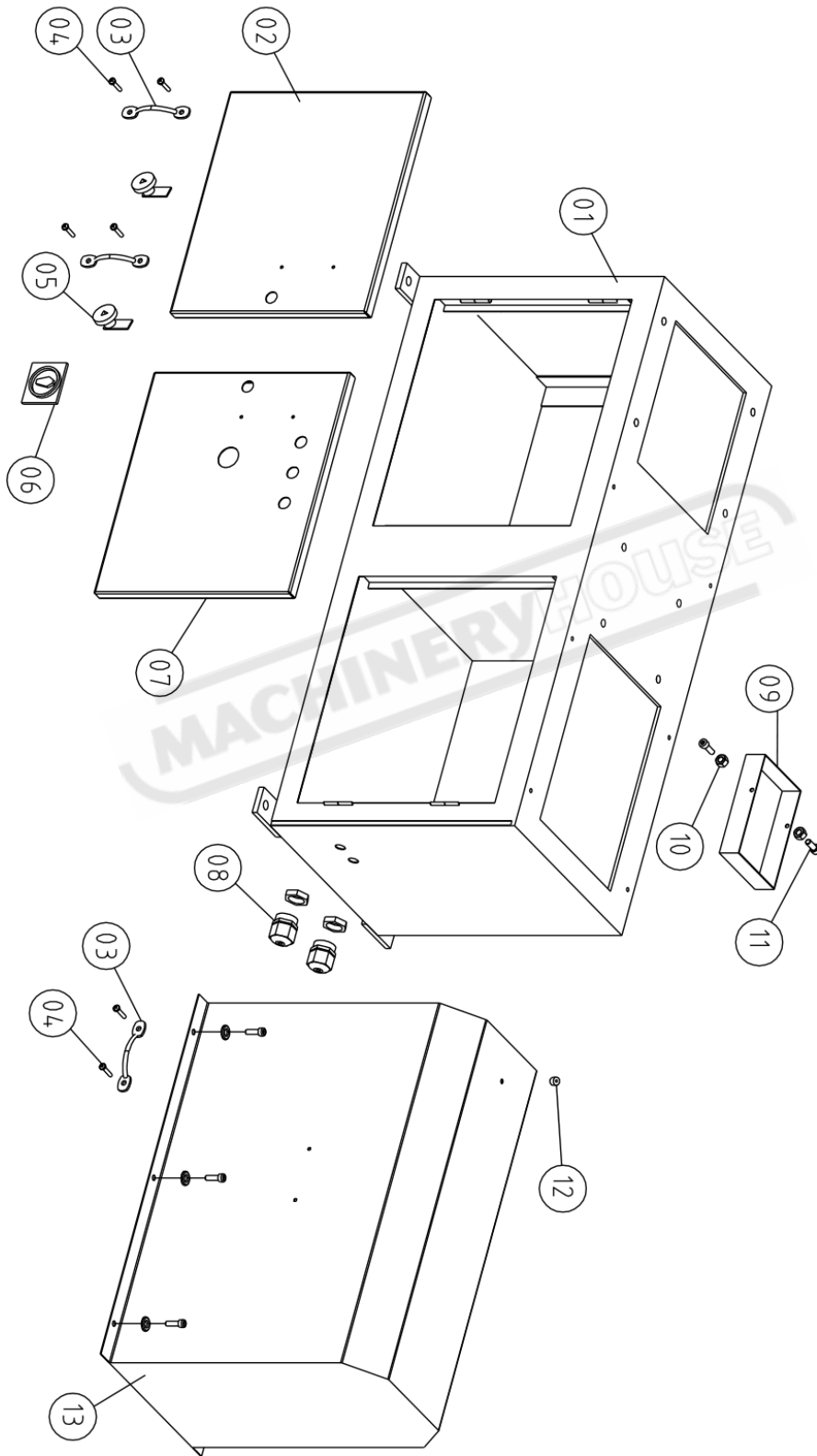

SJM-2.5 SPARE PARTS DIAGRAM

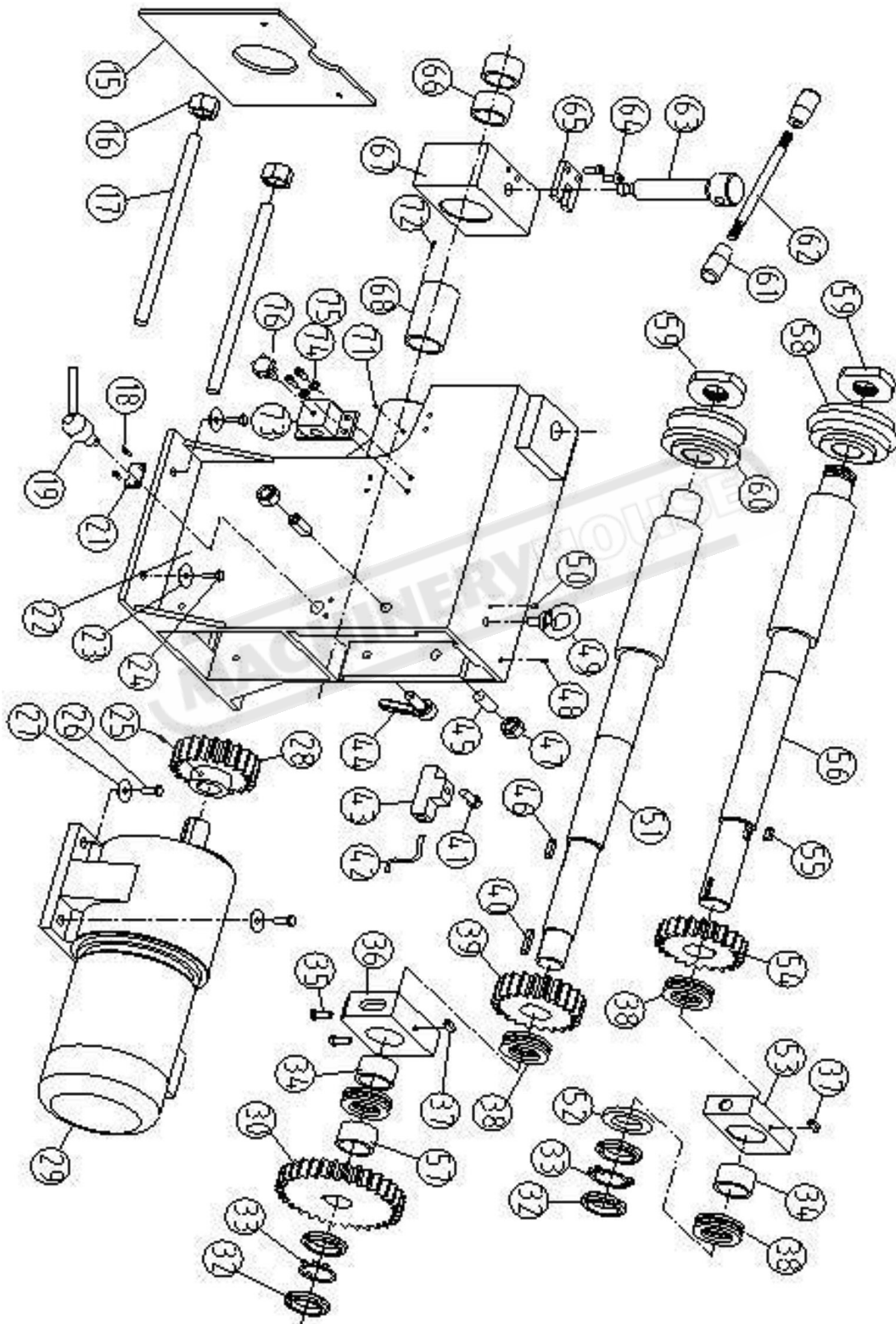

SJM-2.5 SPARE PARTS LIST

ITEM	DESCRIPTION	QTY.	ITEM	DESCRIPTION	QTY.
1	BASE	1	42	TRANSFER PIPE	1
2	LEFT COVER	1	43	BLOCK	1
3	HANDLE	4	44	ADJUSTING HANDLE	1
4	SCREW	8	45	SCREW M20X60	2
5	SAFETY LOCK	1	46	FLAT KEY 14X36	1
6	KNOB	1	47	NUT M20	2
7	RIGHT COVER	1	48	OIL CUP M8	1
8	TOW	2	49	SCREW M16	1
9	OIL BOX	1	50	OIL CUP 8	1
10	NUT	2	51	LOWER SHAFT	1
11	BOLT	2	52	PAD	1
12	OIL CUP	2	53	BACK SEAT	1
13	SAFETY GUARD	1	54	GEAR	1
14	SCREW	6	55	FLAT KEY 14X28	1
14.1	WASHER	6	56	UPPER SHAFT	1
15	STOP PLATE	1	57	SLEEVE	1
16	NUT M10	2	58	UPPER ROLLER	1
17	SLIDE SHAFT	2	59	NUT	2
18	SCREW	2	60	LOWER ROLLER	1
19	ECCENTRIC SHAFT	1	61	HANDLE BALL	2
20	BUSH	1	62	HANDLE LEVER	1
21	PLATE	1	63	SCREW ROD	1
22	BODY	1	64	SCREW	2
23	WASHER	4	65	STOP	1
24	BOLT M16X35	4	66	BEARING	2
25	SCREW	1	67	FRONT SEAT	1
26	BOLT M16X35	4	68	LOWER SLEEVE	1
27	WASHER M16	4	71	OIL CUP 8	1
28	GEAR	1	72	SCREW M8X12	2
29	REDUCER	1	73	APRON BLOCK	2
30	GEAR	1	74	WASHER M8	4
32	ROUND NUT	4	75	SCREW M8X25	4
33	LOCKING RING	2	76	STAR-HANDLE M10	2
34	BEARING	2			
35	SCREW	2			
36	BEARING SEAT	1			
37	BLOCK	2			
38	BEARING 51210	4			
39	GEAR	1			
40	FLAT KEY	1			
41	BOLT	2			

SJM-4.0 CABINET DIAGRAM

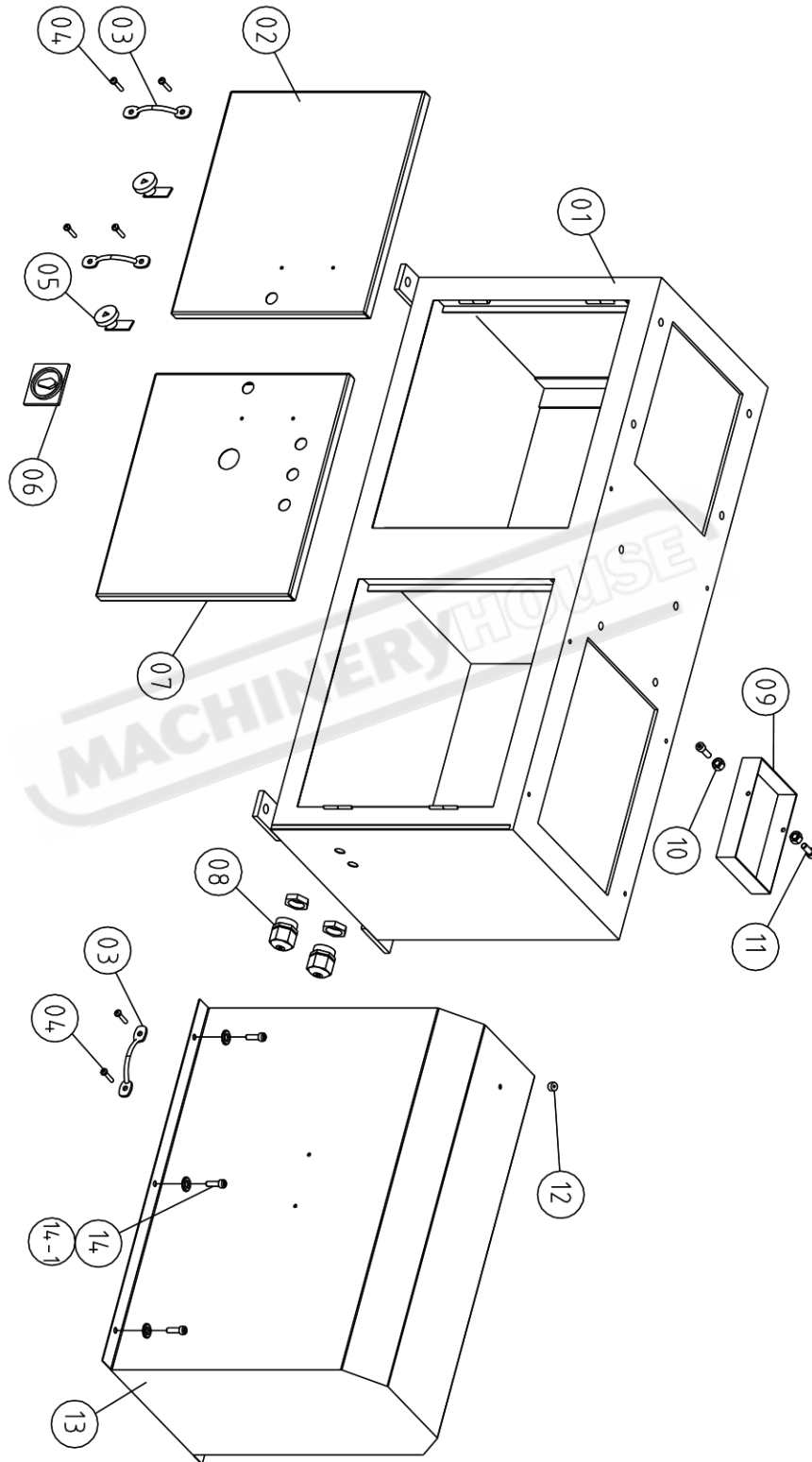

SJM-4.0 SPARE PARTS DIAGRAM

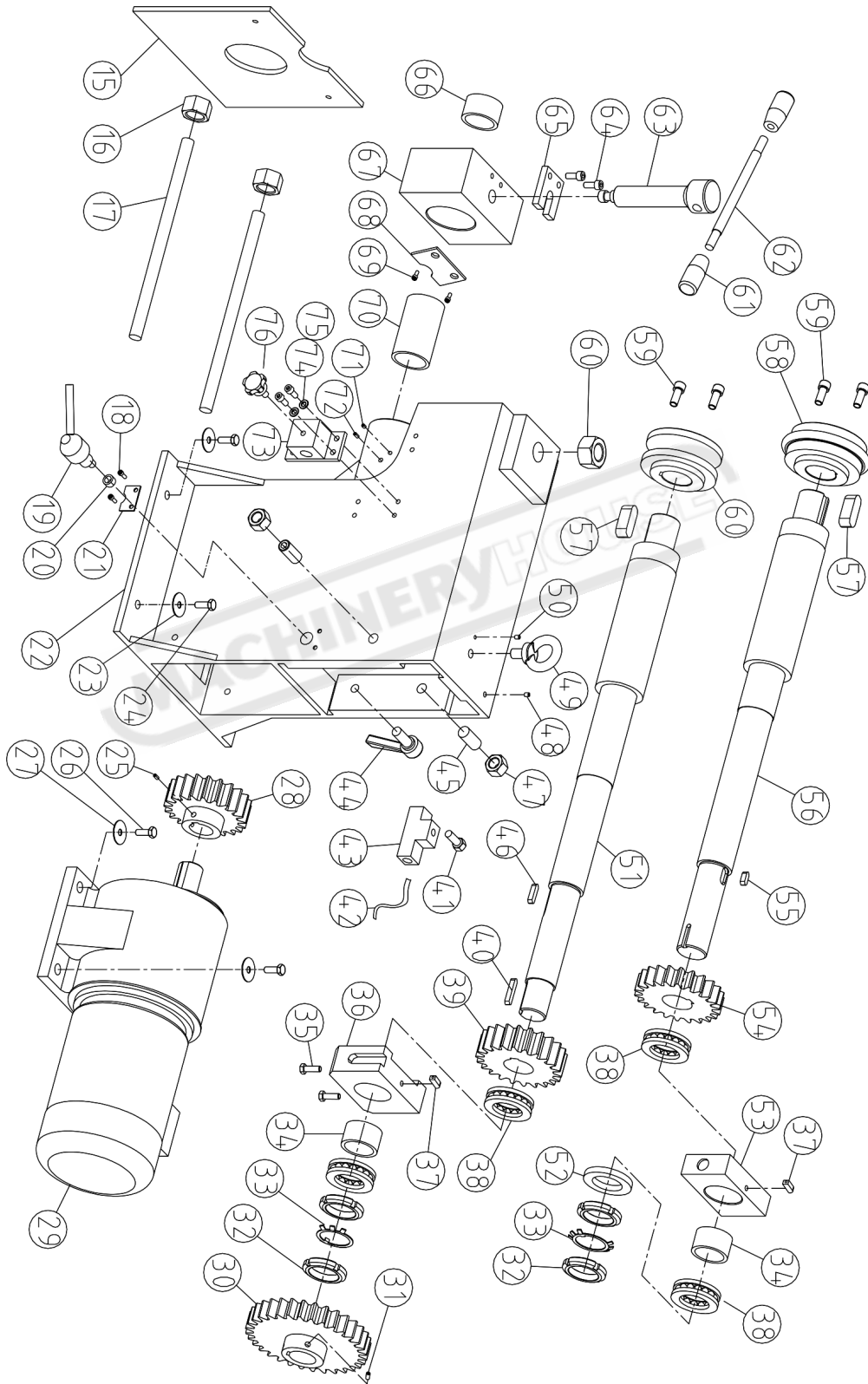

SJM-4.0 SPARE PARTS LIST

ITEM	DESCRIPTION	QTY.	ITEM	DESCRIPTION	QTY.
1	BASE	1	42	TRANSFER PIPE	1
2	LEFT COVER	1	43	BLOCK	1
3	HANDLE	4	44	ADJUSTING HANDLE	1
4	SCREW	8	45	SCREW M20X60	2
5	SAFETY LOCK	1	46	FLAT KEY 14X36	1
6	KNOB	1	47	NUT M20	2
7	RIGHT COVER	1	48	OIL CUP M8	1
8	TOW	2	49	SCREW M16	1
9	OIL BOX	1	50	OIL CUP 8	1
10	NUT	2	51	LOWER SHAFT	1
11	BOLT	2	52	PAD	1
12	OIL CUP	2	53	BACK SEAT	1
13	SAFETY GUARD	1	54	GEAR	1
14	SCREW	6	55	FLAT KEY 14X28	1
14.1	WASHER	6	56	UPPER SHAFT	1
15	STOP PLATE	1	57	SLEEVE	1
16	NUT M10	2	58	UPPER ROLLER	1
17	SLIDE SHAFT	2	59	NUT	2
18	SCREW	2	60	LOWER ROLLER	1
19	ECCENTRIC SHAFT	1	61	HANDLE BALL	2
20	BUSH	1	62	HANDLE LEVER	1
21	PLATE	1	63	SCREW ROD	1
22	BODY	1	64	SCREW	2
23	WASHER	4	65	STOP	1
24	BOLT M16X35	4	66	BEARING	2
25	SCREW	1	67	FRONT SEAT	1
26	BOLT M16X35	4	68	LOWER SLEEVE	1
27	WASHER M16	4	71	OIL CUP 8	1
28	GEAR	1	72	SCREW M8XL2	2
29	REDUCER	1	73	APRON BLOCK	2
30	GEAR	1	74	WASHER 8	4
32	ROUND NUT	4	75	SCREW M8X25	4
33	LOCKING RING	2	76	STAR-HANDLE M10	2
34	BEARING	2			
35	SCREW	2			
36	BEARING SEAT	1			
37	BLOCK	2			
38	BEARING 51210	4			
39	GEAR	1			
40	FLAT KEY	1			
41	BOLT	2			

WARNING

General Machinery Safety Instructions

Machinery House
requires you to read this entire Manual before using this machine.

- 1. Read the entire Manual before starting machinery.** Machinery may cause serious injury if not correctly used.
- 2. Always use correct hearing protection when operating machinery.** Machinery noise may cause permanent hearing damage.
- 3. Machinery must never be used when tired, or under the influence of drugs or alcohol.** When running machinery you must be alert at all times.
- 4. Wear correct Clothing.** At all times remove all loose clothing, necklaces, rings, jewelry, etc. Long hair must be contained in a hair net. Non-slip protective footwear must be worn.
- 5. Always wear correct respirators around fumes or dust when operating machinery.** Machinery fumes & dust can cause serious respiratory illness. Dust extractors must be used where applicable.
- 6. Always wear correct safety glasses.** When machining you must use the correct eye protection to prevent injuring your eyes.
- 7. Keep work clean and make sure you have good lighting.** Cluttered and dark shadows may cause accidents.
- 8. Personnel must be properly trained or well supervised when operating machinery.** Make sure you have clear and safe understanding of the machine you are operating.
- 9. Keep children and visitors away.** Make sure children and visitors are at a safe distance for you work area.
- 10. Keep your workshop childproof.** Use padlocks, Turn off master power switches and remove start switch keys.
- 11. Never leave machine unattended.** Turn power off and wait till machine has come to a complete stop before leaving the machine unattended.
- 12. Make a safe working environment.** Do not use machine in a damp, wet area, or where flammable or noxious fumes may exist.
- 13. Disconnect main power before service machine.** Make sure power switch is in the off position before re-connecting.
- 14. Use correct amperage extension cords.** Undersized extension cords overheat and lose power. Replace extension cords if they become damaged.
- 15. Keep machine well maintained.** Keep blades sharp and clean for best and safest performance. Follow instructions when lubricating and changing accessories.
- 16. Keep machine well guarded.** Make sure guards on machine are in place and are all working correctly.
- 17. Do not overreach.** Keep proper footing and balance at all times.
- 18. Secure workpiece.** Use clamps or a vice to hold the workpiece where practical. Keeping the workpiece secure will free up your hand to operate the machine and will protect hand from injury.
- 19. Check machine over before operating.** Check machine for damaged parts, loose bolts, Keys and wrenches left on machine and any other conditions that may effect the machines operation. Repair and replace damaged parts.
- 20. Use recommended accessories.** Refer to instruction manual or ask correct service officer when using accessories. The use of improper accessories may cause the risk of injury.
- 21. Do not force machinery.** Work at the speed and capacity at which the machine or accessory was designed.
- 22. Use correct lifting practice.** Always use the correct lifting methods when using machinery. Incorrect lifting methods can cause serious injury.
- 23. Lock mobile bases.** Make sure any mobile bases are locked before using machine.
- 24. Allergic reactions.** Certain metal shavings and cutting fluids may cause an allergic reaction in people and animals, especially when cutting as the fumes can be inhaled. Make sure you know what type of metal and cutting fluid you will be exposed to and how to avoid contamination.
- 25. Call for help.** If at any time you experience difficulties, stop the machine and call you nearest branch service department for help.

WARNING

Swage & Jenny Machine Safety Instructions

Machinery House
requires you to read this entire Manual before using this machine.

- 1. Maintenance.** Make sure the Swage & Jenny is turned off and disconnect from the main power supply and make sure all moving parts have come to a complete stop before any inspection, adjustment or maintenance is carried out.
- 2. Swage & Jenny Condition.** A Swage & Jenny must be maintained for a proper working condition. Never operate a Swage & Jenny that has damaged or worn parts. Scheduled routine maintenance should be performed on a scheduled basis.
- 3. Roll Condition.** Never operate a Swage & Jenny with a damaged or badly worn rolls. Replace if required. Rolls should never be greased or lubricated as rolls will slip the material and will not bend.
- 4. Roll Direction.** Be aware of the correct rotational axis of the motor when a qualified electrician connects the Machine.
- 5. Hand Hazard.** Keep hands and fingers clear from moving parts. Serious injury can occur if hand or finger tips get pinched by rolls and can be dragged into machine.
- 6. Personal Protection.** Gloves, safety glasses and safety hat are recommended during operation.
- 7. Avoiding Entanglement.** Swage & Jenny guards must be used at all times. Tie up long hair and use the correct hair nets to avoid any entanglement with the Swage & Jenny moving parts.
- 8. Understand the machines controls.** Make sure you understand the use and operation of all controls.
- 9. Trained Operator.** This machine must be operated by authorized and trained personnel.
- 10. Power outage.** In the event of a power failure during use of the machine, turn off all switches to avoid possible sudden start up once power is restored.
- 11. Work area hazards.** Keep the area around the Swage & Jenny clean from oil, tools, chips. Pay attention to other persons in the area and know what is going on around the area to ensure unintended accidents.
- 12. Guards.** Do not operate Swage & Jenny without the correct guards in place. Necessary guards protect you from injuries by gearbox, motors and other moving gears & parts. The only other area which needs to be carefully monitored during use is the rotational area of the rolls.
- 13. Material condition.** Material must be clean of oil and dry. Oily material can slip and will not bend.
- 14. Material hardness.** Make sure your hardness is the same throughout the material, we recommend that you use certified material. Never bend hard steel, glass or fragile material on this machine.
- 15. Feeding material.** Making a tight bend in one pass is not possible. So you need several passes before you can achieve a certain radius. Tighter curves and full radius always need more passes.
- 16. Stopping the Rolls.** Do not stop or slow the rolls with your hand or workpiece. Allow the Swage & Jenny to stop on its own.
- 17. Emergency stop.** Use the emergency stop button in case of any emergency.
- 18. Hearing protection and hazards.** Always wear hearing protection as noise generated from machine and workpiece can cause permanent hearing loss over time.
- 19. Call for help.** If at any time you experience difficulties, stop the machine and call your nearest branch service department for help.

PLANT SAFETY PROGRAM

NEW MACHINERY HAZARD IDENTIFICATION, ASSESSMENT & CONTROL

Swage & Jenny Machine

Developed in Co-operation Between A.W.I.S.A and Australia Chamber of Manufactures
This program is based upon the Safe Work Australia, Code of Practice - Managing Risks of Plant in the Workplace (WHSA 2011 No10)

Item No.	Hazard Identification	Hazard Assessment	Risk Control Strategies <small>(Recommended for Purchase / Buyer / User)</small>
A	ENTANGLEMENT	HIGH	Eliminate, avoid loose clothing / Long hair etc.
B	CRUSHING	LOW	Secure & support work material. Ensure machine is bolted down.
C	CUTTING, STABBING, PUNCTURING.	MEDIUM	Isolate power to machine prior to any checks or maintenance being carried out. Do not adjust or clean until the machine has fully stopped. Wear gloves to prevent cuts from material.
D	SHEARING	MEDIUM	Isolate power to machine when checks or maintenance is being carried out. Make sure all guards are secured shut when machine is on. Hands should be kept clear of moving parts such as rolls etc.
F	STRIKING	MEDIUM	Ensure area is kept clear of material being rolled.
H	ELECTRICAL	MEDIUM	All electrical enclosures should only be opened with a tool that is not to be kept with the machine. Machine should be installed & checked by a Licensed Electrician.
O	OTHER HAZARDS, NOISE.	LOW	Wear hearing protection as required.
Plant Safety Program to be read in conjunction with manufactures instructions			



www.machineryhouse.com.au



www.machineryhouse.co.nz

Authorised and signed by:
Safety officer:

Manager:

[Signature]

Revised Date: 12th March 2012